

TECHNICAL INFORMATION

WATERSTOPS

PRODUCT NAME

INJECTO™ Tube

Groutable Hose Waterstop System

MANUFACTURER

De Neef Construction Chemicals, Inc.
5610 Brystone Drive
Houston, TX 77041
1(800) 732-0166

PRODUCT DESCRIPTION

INJECTO™ Tube is a preventative waterstop system consisting of a yellow, spiral formed wire tube, covered its full length by a reinforced membrane and filter, with a diameter of ½" (12mm). The tube acts as a delivery system for waterproofing resins that are injected into the structure after concreting is completed; thus permanently sealing the interfaces and voids within construction joints, pipe penetrations, slurry walls, and slab connections. Where old to new concrete walls and slabs will join, an **INJECTO™ Tube** can be easily installed. When water is found infiltrating into the tube, a De Neef injection grout is injected into the system, which cures to a flexible fully bonded rubber seal.

Side Diameter of 12mm

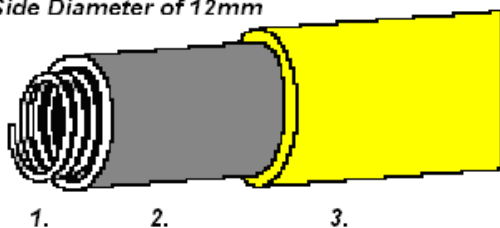

Tube Construction

1. A reinforced spiral of steel wire on the inside prevents collapse of the tube and thus preventing blockage of the 360-degree injection channel.
2. A non-woven filtering membrane prevents even the smallest cement particles from entering the system during the concreting operation. It

TYPICAL PROPERTIES

Property	Values
Outside diameter	1/2 inch
Inside diameter	5/16 inch
Length	Max. 25 Lf.
Weight	4.5 lbs per 25 lf.
Operating temperature	Up to 70°C
Tensile strength steel wire	Approx. 1800 N/mm ²
Diameter filter pores	35 µm

The data shown above reflects typical results based on laboratory testing under controlled conditions. Reasonable variations from the data shown above may result.

Tube Construction cont.

allows free flow and exfiltration of the resin during injection of the tube.

3. Durable outer synthetic membrane protects the inner filtering membrane. The injection pressure makes the fiber of the outer membrane act like a valve to allow the injection grout to penetrate well into the voids and honeycombs in the concrete, throughout the full length of the waterstop. **INJECTO™ Tube** is very suitable for the injection of **HYDRO ACTIVE®** polyurethane resins or with **Superflex** acrylate copolymer resin.

APPROPRIATE APPLICATIONS

- Sealing of cold and construction joints, pipe penetrations, joints between slurry walls and slabs through post injection of the tube with various De Neef resin.

ADVANTAGES

- No leak **INJECTO™** System Warranty
- Simple installation - complete kit.
- **INJECTO™ Tube** can be adapted on site to the exact length of the construction joint (recommended cut length is 25 Lf. max.).
- No special equipment required.
- Injection can be performed at any given time.
- When **INJECTO™ Tube** is injected the pressure of dispersion of the resin is equal over the full length of the tube.
- The system allows injection under relative low pressure.
- There is no interruption of the building activities when **INJECTO™ Tube** is installed.
- Extremely fast installation
- Permanent seal after injection.
- No leak, no injection necessary.
- Forming costs are greatly reduced, compared to conventional rubber waterstops.

PACKAGING

INJECTO™ Tube is supplied in 100 Lf. (non-assembled) kits to allow the system to be adapted to length on site. **The** maximum recommended cut length of **INJECTO™ Tube** to be installed on site is 25 lineal feet (see figure #1)

Reinforced PVC-Tubing: 12 Lf.

Blue trumpets: 12 pieces.

Anchoring clips: 100 pieces.

1 Pallet = 40x100 Lf. kits = 4000 Lf.

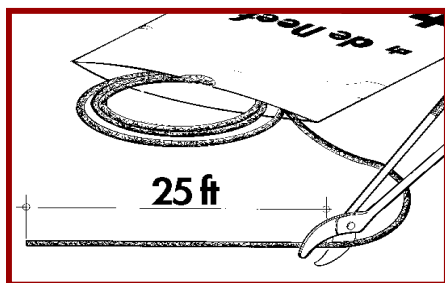

Figure 1

LIMITATIONS

INJECTO™ Tube waterstop system should be installed by an Approved De Neef **INJECTO™** Applicator in accordance with the **INJECTO™** Manual.

SURFACE PREPARATION

Refer to De Neef **INJECTO™** Applicators Manual for more details.

INSTALLATION PROCEDURES

The **INJECTO™ Tube** is installed onto the hardened concrete during formwork installation. In case of rough surfaces, the gap between **INJECTO™ Tube** and the surface should be filled with **SWELLSEAL® Mastic**. **INJECTO™ Tube** will be cut to the required length (recommended cut length is 20–25 Lf see figure 1). The cut ends need to be smoothed with a twist.

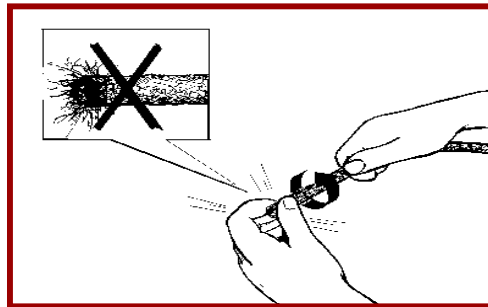

Figure 2

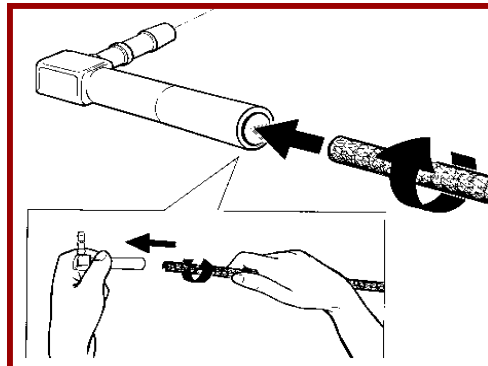

Figure 3

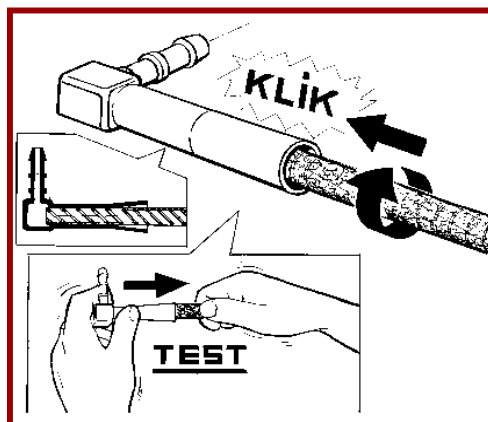

Figure 4

The blue trumpets are installed over the yellow **INJECTO™ Tube** and screwed down to the stop mark inside the trumpet.

The **INJECTO™ Tube** is attached to the concrete with the anchoring clips between the inner and outer reinforcing bars. Nail the anchoring clips down with steel nails every 12 inches (see figures 5 & 6)

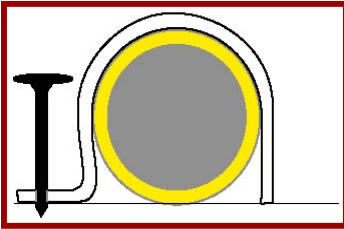

Figure 5

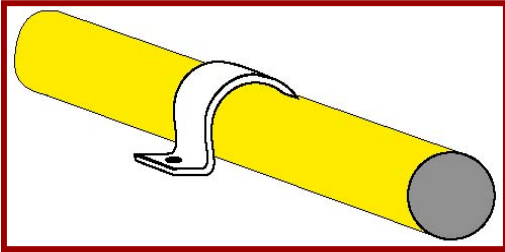

Figure 6

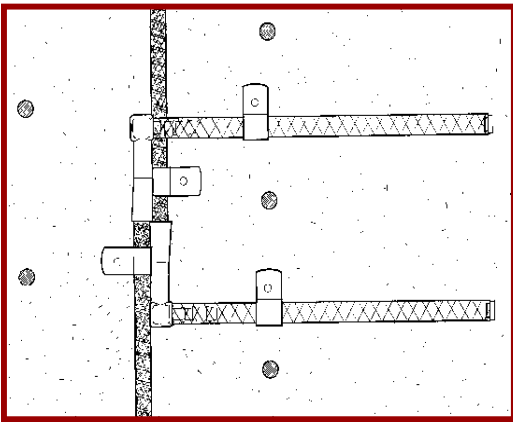

Figure 7

The blue trumpets and PVC tubes are connected and overlapped as in figure 7. The PVC tubes open ends are sealed with a plastic cap as in figure 8 or tape prior to erecting the formwork.

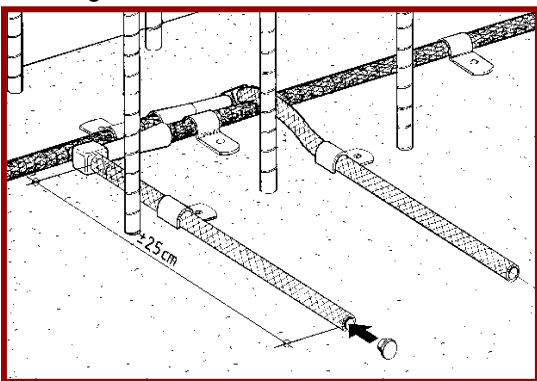

Figure 8

The **INJECTO™ Tube** can also be attached directly to the reinforcement bars with steel tie wire. The PVC injection tubes and ports need to protrude out of the concrete at places, which are easily visible and accessible after the forms are stripped to allow continuous injection.

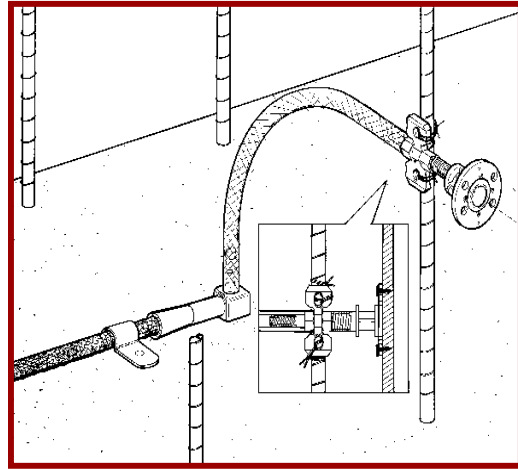

Figure 9, Form Port

The ports can be attached to the formwork with the special **INJECTO™ Tube** form packers. These can be either nailed to wooden formwork or attached to the rebar with steel tie wire if metal forms are used. For an efficient system installation on horizontal surfaces, it is advisable, that a strip of newly poured concrete from $\frac{3}{4}$ to 1 inch be trowel leveled at the time of the pour. Thus allowing the attachment of the clips that hold the system flat, to be more efficient. **INJECTO™ Tube** must be installed in direct contact with the joint over its full length, to allow proper and complete distribution of the injection resin. The ends of the consecutive **INJECTO™ Tube** must have an overlap as seen on figures 7 and 8 to prevent shadowing during the resin injection process. After concrete has cured for the recommended 28 days, if any water infiltrates into the joint it will be collected by the system and shall appear through the reinforced PVC tubing. The tubing should either protrude out of the concrete at easily accessible places or be connected to a form packer. The tube then acts as a delivery system for waterproofing resins, which are injected into the structure in accordance with the De Neef **INJECTO™** Application Manual and the instructions found in the selected injection resins technical data sheets. Consult with the De Neef Technical Department for assistance in selecting the appropriate sealing resin for each condition. **INJECTO™ Tube** is ideal for unique and problem details such as pipe penetrations and attaching to conventional PVC waterstops that may encounter very high head pressures (see figures 10 and 11).

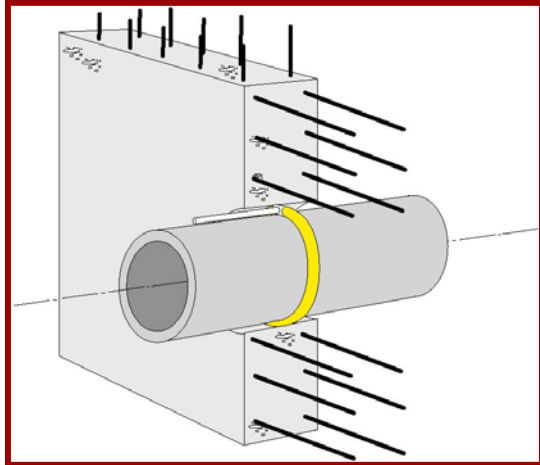

Figure 10, Pipe Sealing

STORAGE & HANDLING

Unlimited shelf life when stored in a dry place.

PRECAUTIONS

Always use protective clothing, gloves and goggles consistent with OSHA regulations during use. Avoid eye and skin contact. Do not ingest. Refer to Material Safety Data Sheet for detailed safety precautions.

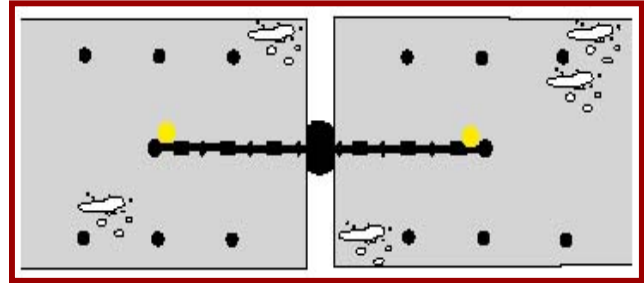

Figure 11, PVC Waterstop

SAFETY INFORMATION

In the event of an EMERGENCY call:
CHEM-TREC 800-424-9300.

WARRANTY INFORMATION

De Neef Construction Chemicals, Inc. products are warranted under the policy set forth under the WARRANTY section of the De Neef Construction Chemicals Inc., product catalog. Warranty information can also be obtained via the De Neef Construction Chemicals Inc. website at www.deneef.com, or by calling 713-896-0123 or toll free at 1-800-732-0166.

Rev. 04/2006