



Systems, Sub-Assemblies



Core Component



Key Component



Peripheral Component

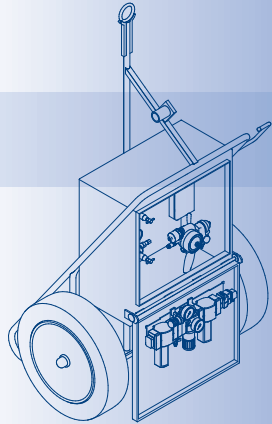

SULZER

Sulzer Metco

Product Data Sheet

Roadrunner™ Mobile Flame Spray System

The only mobile combustion flame spray system that's all-terrain!

Take the many advantages of combustion wire or combustion powder flame spray, put it on wheels and discover exciting new possibilities. Maintenance and repair coating projects that were previously impossible, or impractical to perform without costly and cumbersome staging are now within your grasp.

Roadrunner™ is a complete, transportable, self-contained coating system that is configurable for either the combustion powder Thermospray® process or the combustion wire spray process. It is built from proven Sulzer Metco components, including the 5P-II combustion powder spray gun or the world leading 14E combustion wire spray gun. Designed for heavy duty work, Roadrunner is built for use in remote locations, as well as in-shop.

Roadrunner is ready for duty — anywhere, anytime

It's easy to put Roadrunner profitably to work. Simply connect your customer-supplied gas bottles and air compressor to the Roadrunner and you're set to take on any job where costly field staging or transport back to a fixed workshop is simply not an economical option. Imagine the savings to your customers when you add the capability to perform maintenance and repairs on-site. Or consider how applying a new finish to a piece of operating equipment in the field dramatically reduces downtime.

Roadrunner is compact: at 173 kg (380 lbs.) and a set-up size of 168 cm (66 inches) wide, it goes into spaces inaccessible to other equipment. Roadrunner is the only inexpensive mobile flame spray solution that lets you travel the road to new opportunities.



Roadrunner Cart



*Roadrunner
Mobile Combustion Wire Flame
Spray System*



*Roadrunner
Mobile Combustion Powder Flame
Spray System*

1 General Description

Roadrunner is available as a complete, mobile system:

Roadrunner	Gun	Hose Packages Oxygen, Fuel, Air to Gun		Flowmeter and Control Units	Gas Regulators (non CE only)	Cart
		Non CE	CE			
Wire Spray System Components	Choice of 14E (acetylene, hard wires) 14E-H (acetylene, soft wires) 14E-P (propane, hard wires)	Flowmeter to Gun Choice of: 7H, 10.6 m (35 ft.) 6H, 4.6 m (15 ft.)	Flowmeter to Gun Choice of: 7HEX, 10.6 m (35 ft.) 6HEX, 4.6 m (15 ft.)	3AF Air Flowmeter	Choice of: 3GRA acetylene 3GRP propane	
Powder Spray System Components	5P-II with 5PVA Air Vibrator Unit	Flowmeter to Gun Choice of: 14H, 10.6 m (35 ft.) 12H, 4.6 m (15 ft.)	Flowmeter to Gun Choice of: 14HEX, 10.6 m (35 ft.) 12HEX, 4.6 m (15 ft.)		3GRA acetylene	
Included Common System Components		Regulator to flowmeter 8H, 1.2 m (4 ft.)	Regulator to flowmeter 8HEX, 1.2 m (4 ft.)	3GF Gas Flowmeter 6A Air Control Unit	3GRO oxygen	RR51856

Customers who already own a complete 14E or 5P-II spray system can purchase the Roadrunner RR51856

flame spray cart, which is prepared for mounting of the existing spray equipment.

2 Features and Benefits

- Uses proven technology, packaged in mobile configuration.
- Easily transport all combustion wire flame spray equipment in-house or on-site using the sturdy cart.
- Protective metal storage cabinet holds regulators, flowmeters and stores gun when not in use.
- Cabinet door can be locked open for easy viewing of flowmeters and controls during spray operations.

- Gas bottles securely mount on the back of the truck.
- Wire unit folds in for easy transport and storage.
- Large, heavy-duty tires for easy movement.

Please refer to the appropriate product data sheets for more information on the combustion wire spray guns, flowmeters and wire control and straightening unit.

3 Technical Data

3.1 Dimensions, Specifications

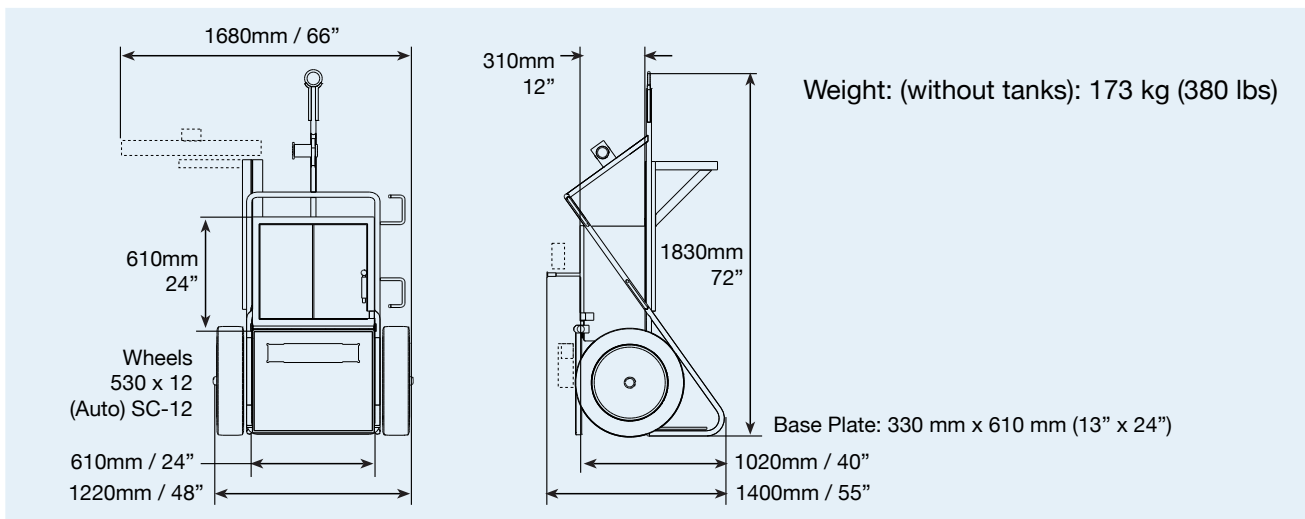

www.sulzermetco.com • info@sulzermetco.com

The Coatings Company™

Sulzer Metco (US) Inc.
1101 Prospect Avenue
Westbury NY 11590
U.S.A.
Tel. +1 516 334 1300
Fax +1 516 338 2414

Sulzer Metco (Japan) Ltd.
3-4-2 Hikawadai, Nerima-ku
Tokyo 179-0084
Japan
Tel. +81 359 203 302
Fax +81 359 203 512

Sulzer Metco Europe GmbH
Am Eisernen Steg 18
D-65795 Hattersheim
Germany
Tel. +49 6190 8090
Fax +49 6190 3009

Sulzer Metco (Switzerland) AG
Rigackerstrasse 16
CH-5610 Wohlen
Switzerland
Tel. +41 56 618 81 81
Fax +41 56 618 81 00

Sulzer Metco (Singapore) Pte.Ltd.
2 Loyang Lane
06-02
Singapore 508913
Tel. +65 6545 0870
Fax +65 6545 0816

Information is subject to change without prior notice.